omeca

Solve Sheet: Model Test -4 (Written + MCQ)

**Written
Mathematics**

01| kã`UłZ Common eYñj A, I, S, T

$$\therefore A \text{ ni qvi m\`ebv} = \frac{{}^2C_1}{{}^9C_1} \times \frac{1}{{}^{10}C_1} = \frac{1}{45}; I \text{ ni qvi m\`ebv} = \frac{1}{{}^9C_1} \times \frac{{}^2C_1}{{}^{10}C_1} = \frac{1}{45}$$

$$S \text{ ni qvi m\`ebv} = \frac{{}^3C_1}{{}^9C_1} \times \frac{{}^3C_1}{{}^{10}C_1} = \frac{1}{10}; T \text{ ni qvi m\`ebv} = \frac{{}^2C_1}{{}^9C_1} \times \frac{{}^3C_1}{{}^{10}C_1} = \frac{1}{15}$$

$$\therefore \text{tguU m\`ebv} = \frac{1}{45} + \frac{1}{45} + \frac{1}{10} + \frac{1}{15} = \frac{19}{90}$$

02| awi, Zvıi i Uvb T

7, 14, 21kg Gi Zi Y h_vıtg f₁, f₂, f

$$T = 7f_1 \text{ ev, } f_1 = \frac{T}{7}; T = 14f_2 \text{ ev, } f_2 = \frac{T}{14}$$

$$21g - 2T = 21f \text{ ev, } f = \frac{21g - 2T}{21}$$

$$\text{Avevi, } f = \frac{f_1 + f_2}{2} \Rightarrow \frac{21g - 2T}{21} = \frac{\frac{T}{7} + \frac{T}{14}}{2} = \frac{3T}{14 \times 2}$$

$$\Rightarrow 7g - \frac{2}{3}T = \frac{3}{4}T; 7g = \frac{8+9}{12}T \text{ ev, } T = \frac{84}{17}g \therefore f = g - \frac{2 \times 84g}{21 \times 17} = \frac{9g}{17} \text{ (Proved).}$$

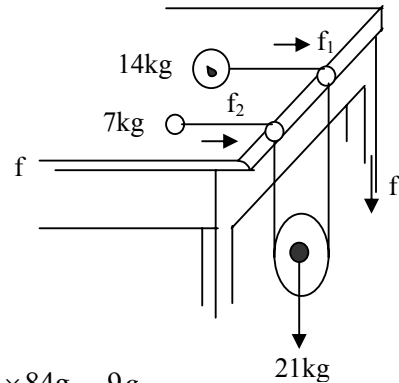

03| $U_n = \frac{2n+1}{n^2(n+1)^2} = \frac{n^2 + (2n+1) - n^2}{n^2(n+1)^2} = \frac{(n+1)^2}{n^2(n+1)^2} - \frac{n^2}{n^2(n+1)^2} = \frac{1}{n^2} - \frac{1}{(n+1)^2} = V_n - V_{n+1}$

$$\therefore S_n = V_1 - V_{n+1} = 1 - \frac{1}{(n+1)^2} \therefore S_\infty = 1 - 0 = 1$$

04| Here in $(x + a)^n$, t₂ = 240, t₃ = 720 and t₄ = 1080

$$\therefore {}^nC_1 x^n a^{-1} = 240 \Rightarrow nx^{n-1}a = 240 \dots \dots (1)$$

$$\Rightarrow {}^nC_2 x^{n-2} a^2 = 720 \Rightarrow \frac{n(n-1)}{2} x^{n-2} a^2 = 720 \text{ and } {}^nC_3 x^{n-3} a^3 = 1080 \Rightarrow \frac{n(n-1)(n-2)}{6} x^{n-3} a^3 = 1080 \dots (3)$$

By solving these three equations, we get, n = 5, x = 2 and a = 3.

05| $T_{r+1} = \frac{-\frac{1}{2} \left(-\frac{1}{2} - 1\right) \left(-\frac{1}{2} - 2\right) \dots \dots \left(-\frac{1}{2} - r + 1\right)}{r!} (-2x)^r = \frac{\frac{1}{2} \left(\frac{1}{2} + 1\right) \left(\frac{1}{2} + 2\right) \dots \dots \left(\frac{1}{2} + r - 1\right)}{r!} (-1)^r 2^r x^r (-1)^r$

$$= \frac{(-1)^{2r} 1.3.5 \dots (2r-1) 2^r x^r}{2^r r!} = \frac{1.3.5 \dots (2r-1)}{r!} x^r = \frac{1.3.5 \dots (2r-1) (2.4.6 \dots 2r)}{r! (2.4.6 \dots 2r)} x^r$$

$$= \frac{2r!}{r! 2^r (1.2.3 \dots r)} x^r = \frac{2r!}{(r!)^2 2^r} x^r; x^r \text{ Gi mnM} = \frac{2r!}{(r!)^2 2^r}$$

06| $D = \begin{vmatrix} \sin px & p \cos px & -p^2 \sin px \\ -p^3 \cos px & p^4 \sin px & p^5 \cos px \\ -p^6 \sin px & -p^7 \cos px & p^8 \sin px \end{vmatrix} = P^9 \begin{vmatrix} \sin px & p \cos px & -p^2 \sin px \\ -\cos px & p \sin px & p^2 \cos px \\ -\sin px & -p \cos px & p^2 \sin px \end{vmatrix}$

$$= -p^9 \begin{vmatrix} \sin px & p \cos px & -p^2 \sin px \\ -\cos px & p \sin px & p^2 \cos px \\ \sin px & p \cos px & -p^2 \sin px \end{vmatrix} = 0$$

$$07) \frac{m+n}{m-n} = \frac{\tan(\theta+\alpha)+\tan(\theta+\beta)}{\tan(\theta+\alpha)-\tan(\theta+\beta)} = \frac{\sin(\theta+\alpha)\cos(\theta+\beta)+\sin(\theta+\beta)\cos(\theta+\alpha)}{\sin(\theta+\alpha)\cos(\theta+\beta)-\cos(\theta+\alpha)\sin(\theta+\beta)} = \frac{\sin(2\theta+\alpha+\beta)}{\sin(\alpha-\beta)}$$

$$\therefore \frac{m+n}{m-n} \cdot \sin^2(\alpha-\beta) = \sin(2\theta+\alpha+\beta) \sin(\alpha-\beta)$$

$$= \sin\{(\theta+\alpha)+(\theta+\beta)\} \sin\{(\theta+\alpha)-(\theta+\beta)\} = \sin^2(\theta+\alpha) - \sin^2(\theta+\beta) \text{ [Showed]}$$

$$08) \int x^2(\ln x)^2 dx = (\ln x)^2 \cdot \frac{x^3}{3} - \int \left(2 \ln x \cdot \frac{1}{x} \cdot \frac{x^3}{3} \right) dx + c_1 = \frac{x^3(\ln x)^2}{3} - \frac{2}{3} \left[\ln x \cdot \frac{x^3}{3} - \int \left(\frac{1}{x} \cdot \frac{x^3}{3} \right) dx \right] + c_2$$

$$= \frac{x^3(\ln x)^2}{3} - \frac{2}{3} \left[\frac{x^3 \ln x}{3} - \frac{x^3}{9} \right] + c = \frac{x^3(\ln x)^2}{3} - \frac{2x^3 \ln x}{9} + \frac{2x^3}{27} + c \text{ (Ans.)}$$

$$09) AC \text{ Gi } Xij = \frac{5}{2} \therefore BD \text{ Gi } Xij = -\frac{2}{5} = \tan \theta \therefore \sin \theta = \frac{2}{\sqrt{29}}, \cos \theta = -\frac{5}{\sqrt{29}}$$

$$r = BE = \frac{1}{2} AC = \frac{1}{2} \sqrt{29} \text{ Ges } E(2, 3/2)$$

$$GLb, \frac{x-2}{\cos \theta} = \frac{y-3/2}{\sin \theta} = \pm r \text{ n}tZ, x = 2 \pm r \cos \theta = 2 \pm \frac{1}{2} \sqrt{29} \left(-\frac{5}{\sqrt{29}} \right) = -\frac{1}{2}, \frac{9}{2}$$

$$y = \frac{3}{2} \pm r \sin \theta = \frac{3}{2} \pm \frac{1}{2} \sqrt{29} \left(\frac{2}{\sqrt{29}} \right) = \frac{5}{2}, \frac{1}{2} \therefore \text{Aci kxl } \theta q, \left(-\frac{1}{2}, \frac{5}{2} \right) \text{ Ges } \left(\frac{9}{2}, \frac{1}{2} \right)$$

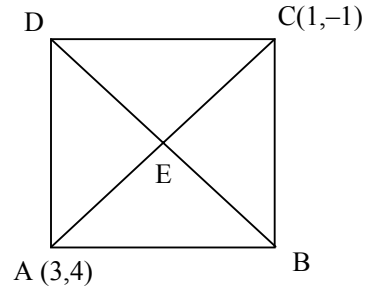

Physics

$$10) \text{ মুক্তিবেগের মান } v_e = \sqrt{2gR} ; \text{ মূল গড়বেগ } C^2 = \frac{3kT}{m} = 2gR \text{ যেখানে } K \text{ হল বোল্জম্যানের ধ্রুবক।}$$

$$\Rightarrow \frac{3kT}{m} = 2gR \Rightarrow T = \frac{2mgR}{3k} \therefore T = \frac{2 \times (2 \times 23.24 \times 10^{-24}) \times 980 \times 6370 \times 10^5}{3 \times 1.37 \times 10^{-16}} = 14.12 \times 10^4 \text{ K (Ans.)}$$

$$11) \text{ } Q = ml_f + ms\Delta\theta + m'l_v = 1 \times 336000 + 1 \times 4200 \times 100 + 0.5 \times 2268000 = 1.89 \times 10^6 \text{ J}$$

$$12) y = 4\sin 2\pi \left(32t + \frac{x}{12} \right) + 4\sin 2\pi \left(32t - \frac{x}{12} \right) = 4\sin \left(\frac{\pi x}{6} + 64\pi t \right) - 4\sin \left(\frac{\pi x}{6} - 64\pi t \right) = 8\cos \frac{\pi x}{6} \cdot \sin 64\pi t \text{ (Ans.)}$$

$$13) I = \frac{10}{40} = 0.25 \text{ A} ; V_{30\Omega} = V_C = IR = 0.25 \times 30 = 7.5 \text{ V} \therefore Q_C = CV_C = 0.5 \times 10^{-6} \times 7.5 = 3.75 \times 10^{-6} \text{ coul. (Ans.)}$$

$$14) KE = \frac{1}{2} mv^2 = 1.57 \times 10^{-13} \therefore v = \sqrt{\frac{2KE}{m}} = 1.37 \times 10^7 \text{ m}^{-1}; BqV = \frac{mV^2}{r} \therefore r = \frac{1.6726 \times 10^{-27} \times 1.37 \times 10^7}{0.954 \times 1.602 \times 10^{-19}} \therefore r = 0.149 \text{ m (Ans.)}$$

$$15) \mu_p \times \sin r_2 = \mu_l \times \sin i_2$$

$$\Rightarrow \sin r_2 = \frac{3\sqrt{2}}{1.5} \times \sin 90^0 ; r_2 = 45^0$$

$$A = r_1 + r_2 \Rightarrow r_1 = 75^0 - 45^0 = 30^0$$

$$\mu_a \times \sin i_1 = \mu_p \times \sin r_1 \Rightarrow 1 \times \sin i_1 = 1.5 \times \sin 30^0 \therefore i_1 = 48.59^0$$

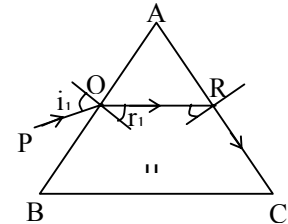

$$16) \text{ আমরা জানি, } \lambda = \frac{a}{d}(x_2 - x_1)$$

$$\text{বা, } a = \frac{\lambda d}{x_2 - x_1} = \frac{5.89 \times 10^{-7} \times 1.6}{4 \times 10^{-3}}$$

$$= 0.236 \times 10^{-3} \text{ m} = 0.236 \text{ m.m. (Ans.)}$$

$$GLb Zi \frac{1}{2} \text{ } \lambda = 5.89 \times 10^{-7} \text{ m}$$

$$\text{Pi } \frac{1}{2} \text{ } \lambda = 1.6 \text{ m ; } \text{ci ci } \text{ } \lambda = 4 \text{ mm} = 4 \times 10^{-3} \text{ m}$$

$$\text{tWi vi } \text{ } \lambda = \frac{16.0}{4} = 4 \text{ mm} = 4 \times 10^{-3} \text{ m}$$

$$\text{Pi } \text{ } \lambda = ?$$

$$17) \text{ আমরা জানি, } Y = \frac{\text{পীড়ন}}{\text{বিকৃতি}}$$

$$F/A = Y \alpha t \text{ [বিকৃতি} = \frac{l \alpha t}{l} = \alpha t], l = \text{রডের দৈর্ঘ্য}$$

$$\left| \frac{C}{5} = \frac{F}{9} \Rightarrow \frac{C}{5} = \frac{50}{9} \Rightarrow C = 27.78^\circ \text{C} \right.$$

$$\therefore \text{পীড়ন} = 1.2 \times 10^{-5} \times 27.78 \times 2 \times 10^{12} = 6.7 \times 10^8 \text{ dyne/cm}^2 \text{ (Ans.)} \approx 6.7 \times 10^7 \text{ Nm}^{-2}$$

$$18) \frac{mv^2}{r} = F_S \Rightarrow m\omega^2 r = \mu_S R \Rightarrow m\omega^2 r = mg \times \mu_S \Rightarrow \omega = \sqrt{\frac{\mu_S g}{r}} \Rightarrow \omega = \sqrt{\frac{9.8 \times 0.3}{0.1}} = 5.42 \text{ rads}^{-1} \text{ (Ans.)}$$

$$04 | \csc \frac{\pi x}{3} \text{ Gi } \int \frac{dx}{3} = \frac{2\pi}{\pi/3} = 6$$

$$\cos \frac{\pi x}{4} \text{ Gi } \int \frac{dx}{4} = \frac{2\pi}{\pi/4} = 8$$

$$\sin \frac{\pi x}{6} \text{ Gi } \int \frac{dx}{6} = \frac{2\pi}{\pi/6} = 12; \text{ mnMmgn (thgb, 4, 3, 5) Gi Dci chiq wofP Kti bvl GLb, 6, 8 Ges 12 Gi}$$

$$j. \text{mv. } = 24, \text{ myZi vs mwZij Zfvte } 4\sin \frac{\pi x}{3} + 3\cos \frac{\pi x}{4} + 5\sin \frac{\pi x}{6} \text{ dviskbwji } \int \frac{dx}{6} = 24 \text{ (Ans.)}$$

$$05 | f'(x) = 2x - \frac{a}{x^2}, f'(x) = 0; 2x - \frac{a}{x^2} = 0$$

$$\therefore x = 2, \text{ we } \int \frac{dx}{x} = 4 - \frac{a}{4} = 0 \Rightarrow a = 16. \text{ (Ans.)}$$

$$06 | i^{4n} = 1 \quad \therefore \text{L.H.S.} = i + \frac{1}{i} = i - i = 0$$

$$07 | \text{awi, mgxKi bwl } x^2 - bx + c = 0 \text{ i wntgi } \int \frac{dx}{x}, b = 10$$

$$\therefore x^2 - bx + 16 = 0$$

$$\text{Kwi } \int \frac{dx}{x}, c = (-9)(-1) = 9$$

$$\therefore \text{mgxKi bwl } x^2 - 10x + 9 = 0 \Rightarrow x = 9, 1$$

$$08 | R = 4\sqrt{3}H \Rightarrow \frac{u^2 \sin 2\alpha}{g} = 4\sqrt{3} \frac{u^2 \sin^2 \alpha}{2g} \Rightarrow \frac{u^2 2\sin \alpha \cos \alpha}{g} = 4\sqrt{3} \frac{u^2 \sin^2 \alpha}{2g}$$

$$\Rightarrow \frac{2\cos \alpha}{1} = 4\sqrt{3} \frac{\sin \alpha}{2} \Rightarrow \tan \alpha = \frac{1}{\sqrt{3}} = \tan 30^\circ \Rightarrow \alpha = 30^\circ$$

$$09 | \cos B = \frac{a^2 + c^2 - b^2}{2ac} = \frac{1}{2} = \cos 60^\circ \quad \therefore B = 60^\circ$$

$$10 | 5x - 12y - 65 = 0 \text{ Ges } 5x - 12y + 26 = 0; \text{ ti Lw} \int \frac{dx}{x} \text{ ga'Kvi } \int \frac{dx}{x} = e^{\int \frac{dx}{x}} \text{ GKw evu}$$

$$\therefore e^{\int \frac{dx}{x}} = \left| \frac{26 + 65}{\sqrt{5^2 + 12^2}} \right| = 49 \text{ eM}^e \text{GKK (Ans.)}$$

$$11 | 2^x + 2^y = 2^{x+y} \Rightarrow \frac{2^x + 2^y}{2^{x+y}} = 1 \Rightarrow 2^{-y} + 2^{-x} = 1 \Rightarrow \left(2^{-y} \frac{dy}{dx} + 2^{-x} \right) (-\ln 2) = 0$$

$$\Rightarrow \frac{dy}{dx} = \frac{-2^{-x}}{2^{-y}} = -2^{y-x} \Rightarrow \left(\frac{dy}{dx} \right)_{x=1, y=1} = -(2)^{1-1} = -2^0 = -1. \text{ (Ans.)}$$

$$12 | \int e^x \frac{x+1}{(x+2)^2} dx = \int e^x \left\{ \frac{1}{x+2} - \frac{1}{(x+2)^2} \right\} dx = \frac{e^x}{x+2} + c \text{ (Ans.)}$$

$$13 | \text{Here } n(C) = 224, n(H) = 240, n(B) = 336$$

$$n(H \cap B) = 64, n(B \cap C) = 80$$

$$n(H \cap C) = 40, n(C \cap H \cap B) = 24$$

$$\therefore n(C^c \cap H^c \cap B^c)$$

$$= n((C \cup H \cup B)^c)$$

$$= n(\cup) - n(C \cup H \cup B)$$

$$= 800 - [n(C) + n(H) + n(B) - n(H \cap C) - n(H \cap B) - n(C \cap B) + n(C \cap H \cap B)]$$

$$= 800 - [224 + 240 + 336 - 64 - 80 - 40 + 24]$$

$$= 800 - (824 - 184)$$

$$= 984 - 824 = 160$$

14) $f = \frac{(1+x)m - (1-x)m}{(1+x)m + (1-x)m} \times g = \frac{gx}{1}$

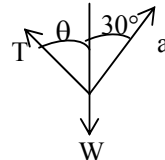
15) 

$$\frac{T}{\sin(\pi - 30^\circ)} = \frac{w}{\sin(\theta + 30^\circ)}$$

$$\Rightarrow T = \frac{w \sin 30^\circ}{\sin(\theta + 30^\circ)}$$

T $\sin(\theta + 30^\circ)$ en $\sin(\theta + 30^\circ)$

$\sin(\theta + 30^\circ)_{\max} = 1 \quad \therefore \theta = 60^\circ$

16) $\frac{9x^2}{144} + \frac{16y^2}{144} = 1 \Rightarrow \frac{x^2}{16} + \frac{y^2}{9} = 1$

$\Rightarrow sp + s'p = 2a = 2 \times 4 = 8$

17) $\sqrt{4^2 + 3^2} = 5$

$\therefore \text{mg} (x-4)^2 + (y-3)^2 = 5^2 \Rightarrow x^2 + y^2 - 8x - 6y = 0$

18) ${}^m C_2 - m = \frac{m!}{(m-2)!2!} - m = \frac{m(m-1) - 2m}{2} = \frac{m(m-3)}{2!}$

19) $\cos \frac{\pi}{3} = \frac{(1+a)}{\sqrt{2}\sqrt{2+a^2}} \Rightarrow \frac{1}{2} = \frac{1+a}{\sqrt{2}(\sqrt{2+a^2})}$

$\Rightarrow a^2 = -4a \Rightarrow a = 0, a = -4$ If $a = -4$ then $\theta = 120^\circ$, So $a = 0$

20) $Qv\hat{w}i \text{ c}\hat{u}g \text{ w}e\text{f}v\hat{t}M \text{ D}\hat{E}x\hat{Y} \text{ b}v \text{ n}l \text{ q}v\hat{i} \text{ m}\hat{a}t\hat{e}b\hat{v} = 1 - \frac{1}{10} = \frac{9}{10}$

$Qv\hat{w}i \text{ w}\hat{O}Zxq \text{ w}e\text{f}v\hat{t}M \text{ D}\hat{E}x\hat{Y} \text{ b}v \text{ n}l \text{ q}v\hat{i} \text{ m}\hat{a}t\hat{e}b\hat{v} = 1 - \frac{3}{5} = \frac{2}{5}$

$Qv\hat{w}i \text{ Z}Zxq \text{ w}e\text{f}v\hat{t}M \text{ D}\hat{E}x\hat{Y} \text{ b}v \text{ n}l \text{ q}v\hat{i} \text{ m}\hat{a}t\hat{e}b\hat{v} = 1 - \frac{1}{4} = \frac{3}{4}$

$\therefore Qv\hat{w}i \text{ AKZKv}\hat{h}\hat{e}n \text{ l} \text{ q}v\hat{i} \text{ m}\hat{a}t\hat{e}b\hat{v} = \frac{9}{10} \times \frac{2}{5} \times \frac{3}{4} = \frac{27}{100}$

21) $\int e^{3 \log x} (x^4+1)^{-1} dx = \int \frac{x^3}{(x^4+1)} dx$

Let, $x^4+1 = z \Rightarrow x^3 dx = \frac{dz}{4}$

$\therefore \int \frac{dz}{4z} = \frac{1}{4} \log z + c = \frac{1}{4} \log(x^4+1) + c$

22) $e^x + e^{-x} = 2 \left(1 + \frac{x^2}{2!} + \frac{x^4}{4!} + \dots \infty \right)$

$\therefore e^{\frac{1}{2}} + e^{-\frac{1}{2}} = 2 \left(1 + \left(\frac{1}{2}\right)^2 \times \frac{1}{2!} + \left(\frac{1}{2}\right)^4 \cdot \frac{1}{4!} \dots \infty \right)$

$\Rightarrow \frac{e^{\frac{1}{2}} + e^{-\frac{1}{2}}}{2} = 1 + \frac{1}{4} \times \frac{1}{2!} + \frac{1}{16} \cdot \frac{1}{4!} \dots \infty \Rightarrow \frac{e+1}{2\sqrt{e}} = 1 + \frac{1}{4} \cdot \frac{1}{2!} + \frac{1}{16} \cdot \frac{1}{4!} \dots \infty$

23) $R = \frac{c}{2 \sin C} = \frac{c}{2 \sin(\pi/2)} = \frac{c}{2} \Rightarrow 2R = c$; Again, $r = (s-c) \cdot \tan \frac{C}{2} = \left(\frac{a+b+c}{2} - c \right) \tan \frac{\pi}{4}$

$\therefore 2r = a+b-c \therefore 2(R+r) = a+b$

24) $\frac{\sin x + 1}{\cos x} = 2 \cos x \Rightarrow (2 \sin x - 1)(\sin x + 1) = 0$

$\Rightarrow \sin x = \frac{1}{2} \Rightarrow x = \frac{\pi}{6}, \frac{5\pi}{6}$

25) $\lim_{x \rightarrow 0} \frac{\left(2 + 2 \frac{x^2}{2!} + \frac{2x^4}{4!} + \dots - \alpha\right) - 2}{x} = 0$

26) $R_1^2 = R_2^2 = R_3^2 = \frac{1}{2}$

NUBWU NUtZ cwti `B fvtel cŭg tUt÷ Rq, 2q tU÷ civRq, 3q tUt÷ Rq A_ev cŭg tUt÷ civRq 2q tUt÷ Rq, ZZrq tUt÷ Rq|

$\therefore \text{tgvU m} = \frac{1}{2} \times \frac{1}{2} \times \frac{1}{2} + \frac{1}{2} \times \frac{1}{2} \times \frac{1}{2} = \frac{1}{4}$

27) $\lim_{x \rightarrow \frac{\pi}{4}} \frac{\sqrt{2} \left(\frac{1}{\sqrt{2}} \sin x - \frac{1}{\sqrt{2}} \cos x \right)}{x - \frac{\pi}{4}} = \lim_{x \rightarrow \frac{\pi}{4}} \frac{\sqrt{2} \sin(x - \frac{\pi}{4})}{x - \frac{\pi}{4}} = \sqrt{2}$

28) $AB = \begin{vmatrix} 1(-1) + 2(-2) & 1(-3) + 2(-4) \\ 3(-1) + 4(-2) & 3(-3) + 4(-4) \end{vmatrix} = \begin{vmatrix} -5 & -11 \\ -11 & -25 \end{vmatrix}$

29) co-factor (mn, YK) of -7 = $\begin{vmatrix} 2 & -3 \\ 5 & 3 \end{vmatrix} = 6 + 15 = 21$

31) $(85)_9 = (77)_{10} \Rightarrow (119)_{16} = (281)_{10} \Rightarrow (63)_8 = (51)_{10}$

32) $1 + nx + \frac{n(n-1)}{2}x^2 + \dots$

$\therefore nx = -\frac{1}{8} \dots \dots \dots (i)$ and $\frac{n(n-1)}{2}x^2 = \frac{3}{8.16} \dots \dots \dots (ii)$

$\frac{(ii)}{(i)^2} \Rightarrow \frac{n-1}{2n} = \frac{3}{8.16} \times 64 = \frac{3}{2} \therefore n = -\frac{1}{2} \therefore x = \frac{1}{4} [(i) \text{ n}tZ]$

$\therefore \left(1 + \frac{1}{4}\right)^{\frac{1}{2}} = \left(\frac{5}{4}\right)^{\frac{1}{2}} = \frac{2}{\sqrt{5}}$

33) awi, ej Ÿq P,Q;P>Q

$\therefore F = P+Q, G = P-Q,$

$\therefore P = \frac{F+G}{2}, Q = \frac{F-G}{2}$

$\therefore P \perp Q \therefore j \ddot{a} = \sqrt{P^2 + Q^2} = \sqrt{\left(\frac{F+G}{2}\right)^2 + \left(\frac{F-G}{2}\right)^2} = \sqrt{\frac{F^2 + G^2}{2}}$

34) $f(x) = \frac{x + \frac{1}{x^2}}{\frac{1}{x^2} + \frac{1}{x}} = \frac{x^3 + 1}{1 + x} = x^2 - x + 1$

$\therefore f = (i^2) = i^4 - i^2 + 1 = 1 - (-1) + 1 = 3$

35) $\left(\frac{x}{2} - b\right)_r.p = \left(\frac{x}{2} - a\right)_p \therefore x = \frac{2(br - a)}{r - 1}$ (Ans.)

$$36| 20 = h - h_1 = \frac{1}{2}gt^2 - \frac{1}{2}g\left(t - \frac{1}{4}\right)^2 = \frac{1}{2} \times 32t^2 - \frac{1}{2} \times 32\left(t - \frac{1}{4}\right)^2 = 8t - 1 \Rightarrow t = \frac{21}{8}$$

$$\therefore h = \frac{1}{2}gt^2 = \frac{1}{2} \times 32 \times \left(\frac{21}{8}\right)^2 = 110.25 \text{ ft}$$

$$37| x = A \sin \omega t$$

$$\Rightarrow \frac{A}{2} = A \sin \omega t$$

$$\Rightarrow \frac{1}{2} = \sin \omega t$$

$$\Rightarrow \omega t = \frac{\pi}{6}$$

$$\Rightarrow t = \frac{\pi}{6\omega} = \frac{\pi \times T}{6 \times 2\pi} = \frac{\pi \times 4}{6 \times 2\pi} = \frac{1}{3} \text{ sec}$$

$$38| R = \frac{\Delta V}{\Delta I} = 0.25 \Omega$$

$$39| \frac{dp}{dT} = \frac{L}{T(V_2 - V_1)} = \frac{10^5 \times 273(-0.091 \times 10^{-3})}{3.4 \times 10^5} = -0.0073^\circ \text{C}$$

$$40| KZKWR = 3 \times 3 + \frac{1}{2} \times 3 \times 3 = 9 + 4.5 = 13.5 \text{ J}$$

$$41| h = -ut + \frac{1}{2}gt^2 = -10 \times 10 + \frac{1}{2} \times 9.8 \times 10^2 = 390 \text{ m}$$

$$42| \mu_k = \frac{f_k}{R} = \frac{6 - ma}{mg} = \frac{6 - 2 \times 2.5}{2 \times 9.8} = 0.05$$

$$43| \alpha = \frac{\omega_f - \omega_i}{t} = \frac{2\pi(f_2 - f_1)}{t} = \frac{2\pi(500 - 300)}{60 \times 5} = 4.1888$$

$$\tau = I\alpha \Rightarrow I = \frac{\tau}{\alpha} = \frac{20}{4.1888} = 4.77 \text{ kgm}^2$$

$$44| t = \frac{d}{u \sin \alpha} = \frac{200}{4 \times \sin 60^\circ} = 57.7 \text{ sec}$$

$$45| \frac{N}{N_0} = \frac{1}{64} = \left(\frac{1}{2}\right)^6 = \left(\frac{1}{2}\right)^n$$

$$\therefore n = 6 \quad T_{1/2} \times n = t$$

$$\Rightarrow T_{1/2} = \frac{60}{6} = 10 \text{ sec}$$

$$46| E = mc^2 = \frac{m_0 c^2}{\sqrt{1 - \left(\frac{0.9c}{c}\right)^2}} = \frac{2.5 \times 10^{-27} \times 3 \times 10^8}{\sqrt{1 - (0.9)^2}} = 5.16 \times 10^{-10} \text{ J}$$

$$47| Z = Z_h \times \frac{M}{n} = 1.05 \times 10^{-8} \times \frac{63.5}{2} = 33.34 \times 10^{-8} \text{ kgC}^{-1}$$

$$48| \bar{E} = \frac{3}{2}kT = \frac{3 \times 1.38 \times 10^{-23} \times (273 + 27)}{2} = 6.21 \times 10^{-21} \text{ J}$$

$$49| n \propto \frac{1}{\sqrt{\rho}}$$

$$\Rightarrow \frac{n_1}{n_2} = \sqrt{\frac{\rho_2}{\rho_1}} = \frac{\sqrt{2}}{1}$$

$$50 | \alpha = 10 \log \frac{I_2}{I_0} = 10 \log \frac{2 \times 10^{-7}}{10^{-12}} = 53.010 \approx 53 \text{ dB}$$

$$51 | n' = \left(\frac{V + V_0}{V - V_s} \right) n = \left(\frac{340 + 20}{340 - 20} \right) \times 480 = 540 \text{ Hz}$$

$$52 | \text{ch}^3 \text{ ej GKB}$$

$$53 | \mu_g = \frac{a \mu_g}{s \mu_w} = \frac{1.5}{1.33} = \frac{C_w}{C_g}$$

$$\Rightarrow \frac{1.5 \times C_g}{1.33} C_w = 2.25 \times 10^8 \text{ ms}^{-1}$$

$$54 | P = P_1 + P_2 = 5 + (-3) = 2 \text{ D}$$

$$55 | \text{Here, } v = -40 \text{ cm, } u = \alpha$$

$$\frac{1}{f} = \frac{1}{v} - \frac{1}{u} \Rightarrow f = -40 \text{ cm} = -0.4 \text{ m.}$$

$$\therefore P = \frac{1}{-0.4} = -2.5 \text{ D}$$

$$56 | P = Fv = 250 \times 9.8 \times 2 = 4900 \text{ W}$$

$$57 | 980 = \frac{1}{2} gt^2$$

$$\Rightarrow t^2 = 2 \times 980 / 9.8 = 200 \therefore t = 14.15 \text{ sec}$$

$$58 | E_1 = \sigma T^4$$

$$227^\circ \text{C} = 227 + 273 = 500 \text{ K and } 727^\circ \text{C} = 727 + 273 = 1000 \text{ K}$$

$$5 = \sigma (500)^4 \text{ and } E_2 = \sigma (1000)^4$$

$$\frac{E_2}{5} = \frac{(1000)^4}{(500)^4} \text{ or } E_2 = 5 \times \left(\frac{10^4}{5^4} \right) = 80$$

$$59 | F = q(\times B) \text{ or } F = qvB \sin \theta \text{ Force will be maximum when } \sin \theta = \text{maximum.}$$

$$60 | S = \frac{I_g}{I - I_g} \cdot G$$

$$\text{Given that } I_g = \frac{I}{20}$$

$$\therefore S = \frac{\frac{I}{20}}{I - \frac{I}{20}} G = \frac{G}{19}$$

$$61 | \omega = \frac{e}{BA n} = \frac{20 \times 10^{-3}}{0.025 \times (12 \times 10^{-2})^2 \times 10} = 5.55 \text{ rad/s}$$

$$62 | \text{We know that, } E = hc/\lambda \text{ or } \lambda = hc/E$$

$$\therefore \lambda = \frac{(6.625 \times 10^{-34}) \times (3 \times 10^8)}{4.0 \times (1.6 \times 10^{-19})} = 3.1 \times 10^{-7} \text{ m} = 310 \text{ nm}$$

$$65 | T = \frac{hpgr}{2 \cos \theta}$$

$$\text{ev, } \theta = 140^\circ \text{ GLvfb, [h (-ve) aiv Ki tZ nte] Kvi Y, Aebgb (cvi t` i)}$$

66) $i = \frac{nE}{nr} = \frac{E}{r}$

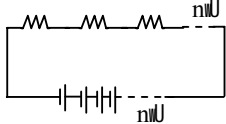

67) $V = \frac{1}{4\pi\epsilon_0} \cdot \frac{q}{r}$
 $= 9 \times 10^9 \times \frac{79 \times 1.6 \times 10^{-19}}{6.6 \times 10^{-15}}$
 $= 17.24 \times 10^6 \text{ V}$

68) $\frac{6}{18} = \frac{10}{20+x}$ তা হলে, চতুর্থ বাহুর সমতুল্য রোধ $S = (20+x)$
 $\Rightarrow \frac{6}{18} = \frac{10}{20+x} \left[\because \frac{P}{Q} = \frac{R}{S} \right]$
 $\Rightarrow \frac{1}{3} = \frac{10}{20+x}$
 $\Rightarrow 20+x = 10 \times 3 = 30$
 $\therefore x = 30 - 20 = 10\Omega$

69) $T_1 V_1^{\gamma-1} = T_2 V_2^{\gamma-1}$
 $\Rightarrow T_2 = T_1 \left(\frac{V_1}{V_2} \right)^{\gamma-1}$
 $\Rightarrow T_2 = 300 \times \left(\frac{V}{\frac{V}{4}} \right)^{1.5-1} = 300 \times (4)^{0.5} = 600\text{K}$
 $\Rightarrow T_2 = 327^\circ\text{C}$ $T_2 - T_1 = 327 - 27 = 300^\circ\text{C}$

70) $\mu_r = 1 + \chi_m = 1 + 499 = 500$
 $\mu = \mu_r \mu_0 = 500 \times (4\pi \times 10^{-7}) = 2\pi \times 10^{-4} \text{ H/m}$

71) flowing current (সিএমএনজি ডিওসি)

72) equal to all the cases (মেসারিটিং মগব নটে)

73) $d = \frac{PM}{RT}$
 $\Rightarrow d = \frac{1.0526 \times 44}{0.0821 \times 373} = 1.513 \text{ gL}^{-1}$

75)

Electron	Neutron
(A) $Al^{3+} = 10$	13
(B) $C = 6$	6
(C) $O^{2-} = 10$	8
(D) $F = 9$	9

77) $5 \text{ g CWB} = \frac{5}{18} \text{ mol CWB}$
 $\therefore \text{ci gvYmsL} = \frac{5}{18} \times 6.023 \times 10^{23} \times 3 = 5 \times 10^{23} \text{ uJ}$

94 | $\text{Na}_2\text{SO}_4 + \text{Ba}(\text{NO}_3)_2 = \text{BaSO}_4 \downarrow + 2\text{NaNO}_3$

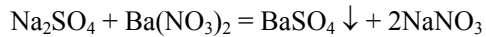

(mv`v)

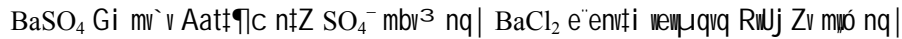

97 | $\text{A}^{\text{vj}} \text{wWnvB} \uparrow \text{Wi mvavi Y mst} \uparrow \text{KZ nj} - \text{C}_n\text{H}_{2n+1}\text{CHO}$

98 | $\text{A}^{\text{vj}} \text{KMnO}_4 \text{ `} \text{e} \uparrow \text{Yi tMvj v} \text{c} \uparrow \text{eY} \text{Ac} \text{mvi Y K} \uparrow \text{i} - \text{wg_vbi} \uparrow \text{qK GumW} \mid$

106 | $\text{NH}_3 \text{ A} \uparrow \text{c} \uparrow \text{v} \text{A}^{\text{vj}} \uparrow \text{d} \uparrow \text{WJK A}^{\text{vj}} \text{wgb mej} \uparrow \text{v} \text{i K} \uparrow \text{K} \uparrow \text{S} \uparrow \text{NH}_3 \text{ A} \uparrow \text{c} \uparrow \text{v} \text{A}^{\text{vj}} \uparrow \text{v} \uparrow \text{t} \uparrow \text{g} \uparrow \text{WJK A}^{\text{vj}} \text{wgb} \uparrow \text{thgb A}^{\text{vj}} \text{wb} \uparrow \text{v} \uparrow \text{b} \uparrow \text{ `} \uparrow \text{e} \uparrow \uparrow \text{v} \text{i K} \mid$

108 | RNA- \uparrow Z Dc \uparrow Z \uparrow K β -D i v \uparrow e \uparrow R |

109 | D is the correct answer. Nobel bequeathed his assets to establish five Nobel Prizes in which Economic Sciences was not included. That's why, it's not a Nobel Prize technically though it's regarded, announced and presented as one in memory of A. Nobel.

110 | D is the correct answer, since in the passage, it is clearly stated that Alfred Nobel was born in Stockholm, Sweden.

111 | C is the correct answer. Whenever two clauses will be connected via "as though", and if the first part is in past indefinite tense, then the latter part will be in past perfect tense.

112 | B is the correct answer, because, everybody, each, everyone – all these refer to singular subject.

113 | A is the correct answer. When verbs like 'have', 'has', 'had', 'get', 'got' etc. act like causative verb in the sentence, then the verb within the bracket would take its past participle form. So, 'cook' will become 'cooked'.

114 | B is the right answer. If, in a simple sentence, there are two verbs, then the verb within the bracket will take an '-ing' with it.

115 | B is the correct answer. A means 'facing death'; B means 'to get relieved by keeping a very small distance of some danger'; C means 'the last source or support'; D means 'a person who is blamed for a bad thing which is done by somebody else'. In term of meaning the most accurate option is B.

116 | C is the correct answer. A means 'rough behaviour'; B means 'the matter of happiness in life'; D means 'a difficult job to do'; and C means 'the last source and support of living in one's life'. In terms of meaning and expression, C is the most relevant option among these.

117 | B is the correct answer. A means 'to confess the truth'; C means 'to be clear, direct and precised'; B means 'to pay attention to every detail of what somebody says'. In term of meaning, B seems to be most relevant.

118 | D is the correct answer. A means 'in the place of'; C means again 'in the place of'; both A and C suggests the idea of replacement. But B means 'eventually'. So, the correct answers are both A and C.

119 | The correct answer is C. The sentence already suggests that the man has such a feature which implies that he is not easily manageable; so, the idiom should be synonymous with 'unmanageable'. A means 'deserving and worthy'; B means 'a mean person'; D means 'chaos'; C means 'something or somebody very tough to deal with'. In term of expression and meaning, C is the most suitable answer.

120 | D is the right answer. A means 'summary of something'; B means 'a mean person'; C means 'each and every detail of a fact'; D means 'relatives or family'. So, the most relevant option is D as other idioms are irrelevant in terms of meaning.